

# Class 125 • Threaded Bonnet • Non-Rising Stem • Threaded Ends

## Gate Valve Figure B-103

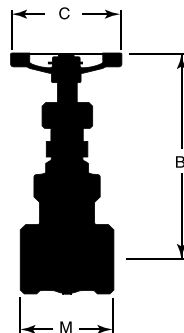
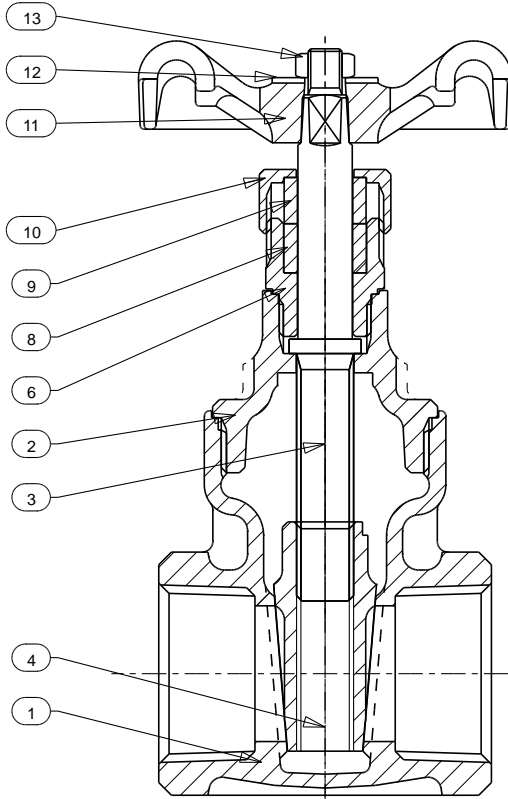

### Materials of Construction

No.	Description	Material	ASTM Spec.
1	Body	Bronze	B-62 C83600
2	Bonnet	Bronze	B-62 C83600
3	Stem	Brass	B-371 69400
4	Disc	Bronze	B-62 C83600
6	Stuffing Box	Brass	B-371 69400
8	Packing Ring	Graphite (Asbestos Free)	
9	Gland	Brass	BSEN12164 CW614N
10	Packing Nut	Brass	BSEN12164 CW614N
11	Handwheel	Malleable Iron	A-197 F22000
12	ID Plate	Aluminum	
13	Handwheel Nut	Brass	BSEN12164 CW614N

#### NOTE:

The addition of the letter "K" at the end of the figure number designates valves assembled & tested in the USA. Materials of Construction & Dimensions are the same.

### Industry Standards

Complies with MSS SP-80 Type 1

See Page 6 for Pressure-Temperature Ratings

### Dimensions and Weights

Inches (millimeters) - Pounds (kilograms)

Valve Size	Dimensions			Wt.
	B	C	M	
¼	2.95	1.75	1.81	0.6
	(75)	(45)	(46)	(0.27)
⅜	2.95	1.75	1.81	0.6
	(75)	(45)	(46)	(0.26)
½	3.23	2.06	1.98	0.8
	(82)	(52)	(51)	(0.35)
¾	3.74	2.56	2.14	1.2
	(95)	(65)	(55)	(0.55)
1	4.64	2.75	2.46	1.8
	(118)	(70)	(63)	(0.84)
1 ¼	5.67	3.06	2.77	2.6
	(144)	(79)	(71)	(1.18)
1 ½	6.53	3.62	2.85	3.6
	(166)	(92)	(73)	(1.66)
2	7.48	4.06	3.25	5.6
	(190)	(103)	(83)	(2.55)
2 ½	9.26	5.28	4.25	12.4
	(235)	(134)	(108)	(5.62)
3	9.89	5.28	4.59	17.4
	(251)	(134)	(117)	(7.89)